



Schlatterer
Esband

**INSTALLATION AND TROUBLESHOOTING
FOR ES BAND GARNITURE AND
SUCTION TAPES**



ESBAND garniture tape installation on cigarette- and filter making machines

ESBAND suction tape installation

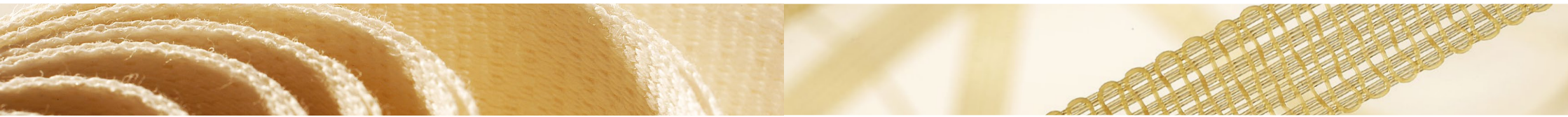

1. Remove old tape
2. Clean garniture area of dust and glue deposits
3. Check for worn or scored garniture parts
4. Check all rollers conveying the tape to make sure that they turn easily
5. Check condition of tape drum lining – if worn out: exchange using new drum lining **Esband NR 22** (grey)
6. Check circumference of tape drum with existing worn tape drum lining still fitted (use a measuring tape).
7. Remove old tape drum lining, fit new **Esband NR 22** (grey) and set to the previous circumference
8. Fit new garniture tape with arrow pointing in the forward direction on the (top) paper side
9. Pull the tape over the garniture and the driving pulley
10. Slip the tape carefully into the middle of the garniture tube
11. Apply correct tension (tension should be between **250 N – 300 N**)
12. Start machine on “slow motion” and adjust lateral tape position
13. Make sure that the garniture tape is running in the middle of the garniture; “guide” the cigarette paper onto the top of the tape
14. Commence feeding the cut tobacco or the tow
15. Recheck tape run and adjust paper position along the tape run
16. Check paper tension adjustment according to operators manual
17. Check if the diameter of the tobacco or filter rod is correct – if a different type of tape is being used, check tape thickness and if necessary, adjust the height of the garniture tongue/shoe
18. If the pressure within the garniture is too high, slightly “lift” the height of the long and short folders by means of shims



1. Remove old suction tape
2. Clean suction channel (removing any build-up of debris that has formed)
3. Check easy turning of all pulleys and ceramic rollers
4. Check cleaning scraper on each roller
5. Check side rails for damage and scoring, exchange if rails are damaged (1)
6. Check scraper, exchange if it is worn (2)
7. Check driving wheel: change if knurling is worn out
8. Check height of the pressure disc, correct setting: cigarette diameter minus 1.1 mm (3 A)
9. Check cleaning block for scoring
10. Check if tensioning device functions correctly
11. Install new tape taking care that the rough side faces the tobacco
12. Set scraper to **0.15 – 0.2 mm** gap between tape and scraper point (3 B)
13. Check correct functioning of air cylinder
14. Check setting of the air pressure of the tensioning device

Important for proper function:	Machine	Polyamid	PEEK
Air pressure should never exceed the above values (bar)	Protos 80	2.0-2.5	2.0
	Protos 90 & 100	3.5-4.0	2.5
	Protos 2	3.5-4.0	2.5
	GD 1-2-1	2.5	2.0
	Protos M5	2.5	2.5
	Protos M8	3.5-4.0	2.5

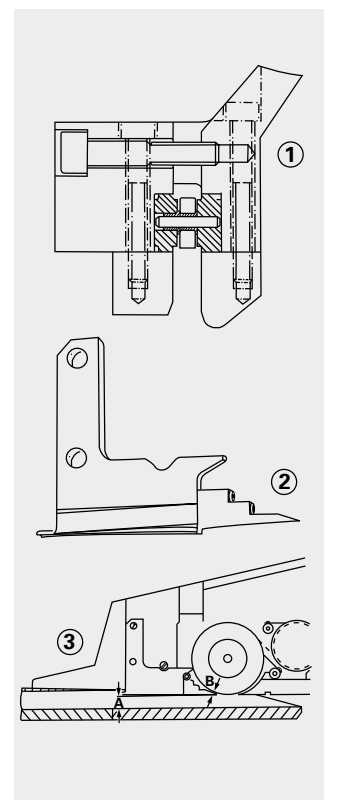

Troubleshooting: Garniture tape problems



Tapes for special cigarettes and filters

The strongest fibre we can produce garniture tapes of, is Kevlar. The advantage of this material is the very high breaking strength which remains also while the temperature increases. Tapes made out of this material are ideal for the production of Kretek cigarettes, special filters and for products produced on older equipment.

Lateral movement / wobble

1. Tape edge burned by the heater
2. Glue on tape edge
3. Drum tyre is worn (grooved)

Paper too loose or too tight

1. Check diameter of driving wheel or offset of speed
2. Check grip tape (drum tyre)

Tape stretch

If the garniture tape appears to stretch

1. Check function and setting of tape tensioning device; tension should not exceed **300 N**
2. Check garniture temperature
3. Check tape length
4. Check position of tensioning device
5. Check if the problem is related to tape length or if there are other causes, e.g. slippage

Tape slippage on tape drum

1. Clean grip tape
2. Check function of tensioning device
3. Exchange grip tape — use endless drum tyre **Esband NR 22** for best performance

Slippage between tape and cigarette rod

1. Increase coefficient by applying chalk to the paper side
2. With special care emery paper can also be used to roughen the tape surface
3. Depending on the characteristics of the paper use different garniture tapes (see graph)

Coefficient of friction paper

Too low:

Slippage results in:

1. length variations
2. diameter variations

Too high:

No compensation of relative movement results in:

1. wrinkles
2. bottom folds
3. uneven filter ends

Different coatings

Plain
(SKO 46.1 or SQO 90)

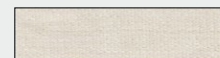

Impregnated
(SKT 43 or SQW 90)

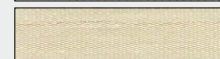

Centre film coating
(SKP 46.23)



Centre latex coating
(SKP 46.2 or SQP 90)



High garniture temperature

1. Check garniture tape running side for deposit of dust or rubber of the drum tyre. If necessary, clean garniture and exchange drum tyre; **Esband NR 22** gives the best performance
2. Check proper operation of the cooling system
3. Air cooling system: check air flow for any blockage and clean air holes
4. Water cooling system: check function of the heat exchanger
5. Check ball bearings on the idler roller
6. Check garniture setting, especially the height of the tongue
7. Check heater setting
8. The temperature should not exceed 85° C on top of the garniture rails

Recommendations for slim and super slim cigarettes and filters

SQO 90

Plain tape for cigarette production on ultra high speed makers. Especially suitable for production of slim cigarettes.

SQP 90

Centre coated tape for filter and multifilter making using medium and highly porous paper qualities.

SQW 90

New coating method for full coating of the tape. For filter and multifilter manufacturing using medium porous and highly porous paper qualities. Predestined for slim charcoal filter production.

Tape tenacity under temperature

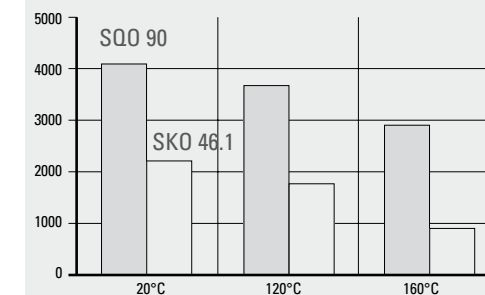

Troubleshooting: Suction tape problems

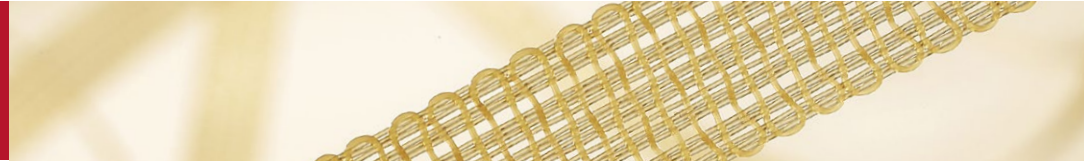

Tobacco chokes

1. Tape holes are blocked with tobacco casing
2. Tape slips on the drive pulley (tape pulley is too polished or worn)
3. Tape tension is too low (test operation of the tension cylinder)
4. Tape stretches too much. Reduce air pressure setting
5. Tobacco moisture exceeds the prescribed limit
6. Shoe/scraper is worn

Bad filling – high standard deviation

1. Tape is fitted incorrectly: rough side must convey the tobacco
2. Tape type unsuitable for the tobacco blend (see graph)
3. The clearance between the shoe/scraper and the suction tape is too big. See installation instructions
4. Shoe/scraper is worn
5. The height of the pressure disc and shoe is set incorrectly. See instructions
6. The pressure disc and shoe are not set in alignment with the garniture
7. The vacuum is too low. Check that the fan is working correctly. Fan blades could be worn

Tobacco wastage too high

1. Tape type unsuitable for the tobacco blend (see graph)
2. Tape guide rail is worn

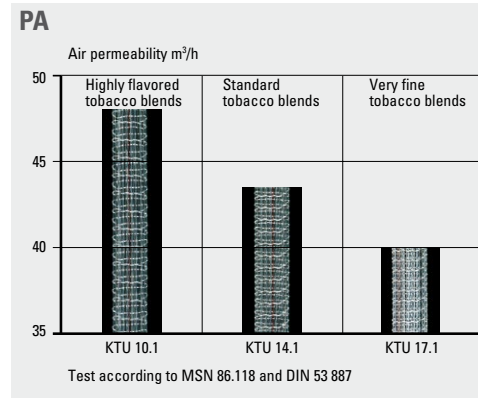

Tape wear

Wear on the edges of the tape:

1. Guide rails worn
2. Inlet guide worn
3. Rough edges in the suction chamber
4. No smooth transition of the rails through the suction chamber

Wear on the running side of the tape:

1. Ceramic rollers do not rotate
2. Ceramic rollers or “ski ramps” are worn out
3. Trimming device cam does not rotate
4. Idler rollers do not run freely
5. Cleaning scraper is not set correctly. Tape rubs against the back of the scraper

PEEK SUCTION TAPES – DIFFERENT SETTINGS

Tape tension

Adjust tape tension at 150 N.

Black threads indicate running direction and must always face the **front side**. Rough side faces tobacco.

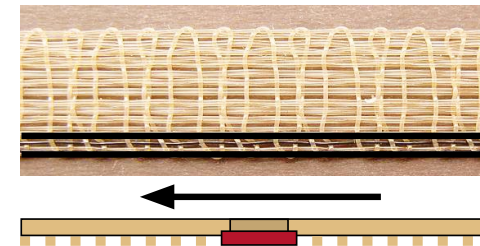

Tape length

The tape is **10 mm – 30 mm longer** than the nominal length. Install tape without tension and move the tension roller by hand to the right in order to avoid the slacking.

Machine setting – scraper

Set gap between tape and scraper-shoe point to: **0.15 mm**

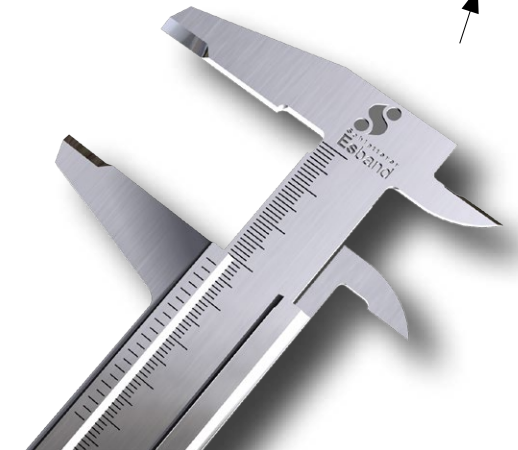
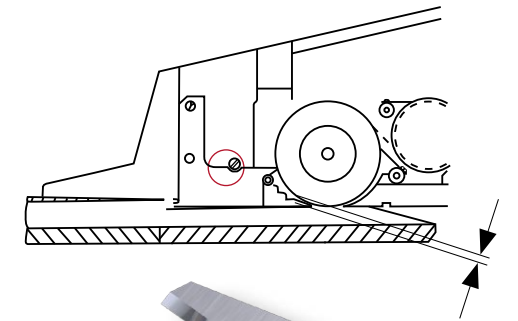



MSC-101.13-E-07-15



**Schlatterer
Esband**

Max Schlatterer
GmbH & Co. KG
Alt-Ulmer-Straße
D-89542 Herbrechtingen
Germany
Phone: +49 (0) 73 24 / 15-0
Fax: +49 (0) 73 24 / 15-280
info@esband.de
www.esband.de

